



# E360 Outlook

Balancing All Aspects of the  
Commercial Refrigeration Industry

## Redefine Refrigeration Reliability



P. 2 Digital Transformation Helps Drive Tighter Cold Chain Integration

P. 8 Raising the Standard

P. 18 Less Is More



## Don't Compromise on Compressor Selection



Refrigeration equipment reliability is more critical today than ever before. As supermarket, restaurant and convenience store retailers face unprecedented changes in the way they do business, their refrigeration requirements are quickly evolving. Modern systems must meet a variety of emerging challenges, such as:

- Supporting small to large store formats
- Complying with food safety and environmental regulations
- Adapting to e-commerce and omnichannel fulfillment requirements
- Integrating with IoT technologies and building management systems
- Achieving energy-efficiency and sustainability goals

### Choose the leader in scroll compression technology

Through our Copeland Scroll™ technology, Emerson has pushed the envelope in refrigeration reliability for decades, and these innovations continue today. Here are just a few of the reasons leading equipment manufacturers partner with Emerson to support their product development initiatives:

- **Superior reliability and energy-efficiency** — Reliability and energy efficiency are among the most important factors to our customers. With 70 percent fewer moving parts and simple internal suction and discharge method, Copeland Scroll compressors deliver reliable, energy-efficient performance, year after year. Its compact and lightweight design allows it to be integrated

in applications where space is limited, without ever sacrificing performance or efficiency.

- **Widest application range:** low- and medium-temperature applications; fractional ( $\frac{3}{4}$ ) to large (17) horsepower capacities; commercial and industrial uses; qualified for low-GWP and natural refrigerants
- **Expert network support:** more than 340 certified Copeland™ technical specialists; large wholesaler network comprised of more than 850 Copeland-authorized wholesaler locations
- **Product development expertise:** application engineering; design, testing and certification services; innovation center proof-of-concepts; app development
- **Based in the U.S.:** when you need customer service, product support or availability, representatives from our U.S. base of operations can quickly deliver the compressor you need

From transport to cold storage, Copeland Scroll compressors are the first choice in every link of the food supply chain. So don't put your company's reputation at risk. Choose the proven dependability of Copeland Scroll compressors.

**Phil Moeller**, Managing Editor, E360 Outlook  
Vice President – Product Management, Refrigeration, Emerson

# CONTENTS

## 2 Digital Transformation Helps Drive Tighter Cold Chain Integration

Digital technologies are transformative in addressing concerns within the cold chain, such as: ensuring the safe handling of perishable foods from farm to table.



## 6 Food Retail Challenges

Energy, environmental and food safety regulations add complexity to every facet of cold chain operations. Rapidly evolving shopping behaviors are driving the emergence of updated, flexible retail formats.

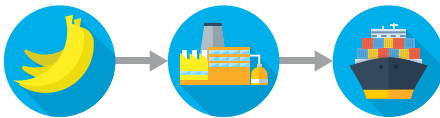

## 8 Raising the Standard

Copeland Scroll™ Refrigeration K5 compressor builds upon foundation of reliability and efficiency.

## 10 The Multiplex Revolution

Low-charge multiplex refrigeration systems are taking on energy, reliability and environmental challenges.

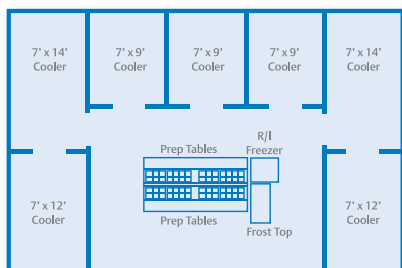

## 12 National Grocery Chain Makes Transition to Transcritical Refrigeration

Phoenix-based grocery chain deploys its first CO<sub>2</sub> transcritical booster system in Atlanta store.



## 16 Restaurant Update

Food quality is a differentiator. Brand reputations are built on the promise of delivering consistently exceptional food and dining experiences.

Consumers demand fresh, healthy convenience.



## 18 Less Is More

Copeland Scroll™ compressors are now available in fractional horsepower range.



## 20 State of the Art Sustainability

Multiplex refrigeration system lays foundation for Café's green mission.



## 24 Copeland Scroll Compressors

The entire line of Copeland Scroll compressors for refrigeration presented with HP, refrigerants, applications and other model information.

### Publisher

Emerson

### Managing Editor

Phil Moeller

### Email Us

Email us at [E360.Climate@Emerson.com](mailto:E360.Climate@Emerson.com) with any comments or suggestions. We would love to hear from you.

### Website

[Climate.Emerson.com/E360](http://Climate.Emerson.com/E360)



# Digital Transformation Helps Drive Tighter Cold Chain Integration



By John Rhodes  
Group President, Cold Chain  
Emerson Commercial & Residential Solutions

# End-to-end data, services and insights



The prevalence of digital technologies with data mining and analytics tools is transforming nearly every facet of the modern economy. Many experts feel we are at the tipping point of an evolutionary process where businesses are realizing the true power and potential of harnessing their abundance of data — first to better serve customers, and secondly to grow market share and improve overall operational performance. It's a concept some have termed the *digital transformation*.

One area where these potential benefits are particularly transformative is in addressing concerns within the cold chain, such as: ensuring the safe handling of perishable foods from farm to table; reducing, controlling and managing energy and associated resources; and maintaining the commercial infrastructures of the grocery, foodservice, processing and distribution industries.

Historically, cold chain stakeholders have made very discrete efforts to improve operations in areas like energy reduction, refrigerant management, safeguarding food and improving human comfort. These important efforts were often spearheaded by single departments or corporate entities focused on very specific outcomes based on their domain of interest or expertise.

Each discrete action represented an important stepping stone as our industry evolved in response to market pressures, such as:

- Transitioning to energy-efficient Copeland Scroll compression technology in refrigerated seagoing containers

- Integrating reliable, vibration-resistant Copeland Scroll compressors in reefer truck containers
- Moving away from high-GWP HFC refrigerants toward more sustainable, environmentally friendly alternatives in commercial refrigeration
- Providing tools for convenience store operators to automate temperature monitoring and record keeping of their expanded food offerings

These all were — and still are — necessary steps toward achieving a more holistic, enterprise-wide perspective.

With the vast amounts of data available today and the computational horsepower to analyze it, business leaders have new opportunities to innovate and bring more comprehensive management to cold chain activities — and provide previously unimaginable value to consumers.

Instead of working within only a refrigeration system to improve energy consumption or merely using controls to enhance comfort, market leaders are looking horizontally across their enterprises and supply chains for broader insights, deeper intelligence and the ability to make more strategic operational decisions.

For those business leaders who have taken steps along the journey of digital transformation, their customers have rewarded their innovations with increasing loyalty — which of course translates into improved market share. These are the companies

---

helping to drive trends and winning the hearts and minds of consumers in the modern marketplace.

The true industry leaders thriving in this brave new world are those who have made the commitment to utilizing all available enterprise data — not simply to exploit sales opportunities, but to form deeper relationships with their customers. It's these leaders who can transform a potentially negative, possibly brand-damaging event into an opportunity to engender customer loyalty.

A very recent example of the potential power of data was the food safety concerns surrounding romaine lettuce, when consumers became ill after purchasing goods in grocery outlets. Many people demanded to know where the contamination occurred. In this case, technology was essential in tracking the instance of contamination to a specific farm, then using both public media and direct contact to notify consumers of the risks and mitigation actions.

The depth of information available represented in this “connected” scenario included the ability to trace food literally from a farm to the consumer’s table. As an example of advanced use of data, some companies were even able to notify their consumers via email or text message to help protect their safety. Doing so required an electronic trail that combined supplier traceability data, store inventory records, POS data, and customer loyalty programs to get information directly and quickly to the consumers who purchased contaminated lettuce.

Using similar data-driven approaches, retail stores are reducing their energy costs during peak demand periods by limiting or avoiding the significant “peak time surcharges” that are assessed when the greatest amounts of energy are required from the local energy provider. In these situations, building management systems (BMS) are set up to receive notices from utility companies when demand reduction opportunities arise. At these times, the BMS can send communication and control instructions automatically through a demand response program that shuts down non-essential equipment and optimizes the use of renewable resources and stored energy. This is not only good from an operational perspective, but also appeals to

***The depth of information available represented in this “connected” scenario included the ability to trace food literally from a farm to the consumer’s table.***

modern consumer preferences for businesses that are making sustainability a core value.

As the industry quickly moves to a more data-driven paradigm, it will undoubtedly discover improved methods of operation and new ways to engage and protect consumers. In recent years, Emerson has focused on expanding our capabilities across every domain within the cold chain to support this shift. Through investments, acquisitions, product development and strategic partnerships, we’ve connected the dots between these areas to create holistic solutions. We’ve also restructured our organization to provide comprehensive solutions for both discrete and complete opportunities, regardless of what role your company plays within the cold chain.

This is an extremely dynamic period in cold chain history. The abundance of data is helping to remove divisions between vertical markets and revealing the true level of interdependence needed to ensure complete cold chain integrity.

To that end, we see a digital transformation occurring before our eyes — not in grandiose, intangible, all-consuming approaches, but in the expansion of existing, proven technologies coupled with the use of emerging digital assets to create new insights and opportunities. We see digital transformation as the increasingly powerful iterative development of connected, adjacent systems accelerating and eventually revolutionizing how companies operate. And, we’re here to help you make this critical cold chain transition a reality for your business. 🌐



# Regulations continue to disrupt

Energy, environmental and food safety regulations add complexity to every facet of cold chain operations.



The average U.S. company spends the equivalent of **21 percent of payroll costs** on regulatory compliance



The DOE is mandating energy reductions from **5 to 50 percent** on various classes of commercial refrigeration equipment



**197 countries** agreed to a global HFC phase-down via the Kigali Amendment to the Montreal Protocol



Estimated annual costs of compliance with the Preventive Controls Rule will be **\$13,000 per facility**

*Enhancing energy efficiency and environmental conservation*

# Significant infrastructure and maintenance impacts

Rapidly evolving shopping behaviors are driving the emergence of updated, flexible retail formats with “always on” availability.



U.S. retailers are **investing billions** annually to update store formats



An estimated **115,000 technicians** will be needed in HVACR by 2022



Workforce demographics are **increasing pressures** on an already dwindling skilled technician pool



**New strategies** are needed to minimize service disruptions

*Creating sustainable infrastructure*



# Emerson has solutions for critical areas, applications and markets

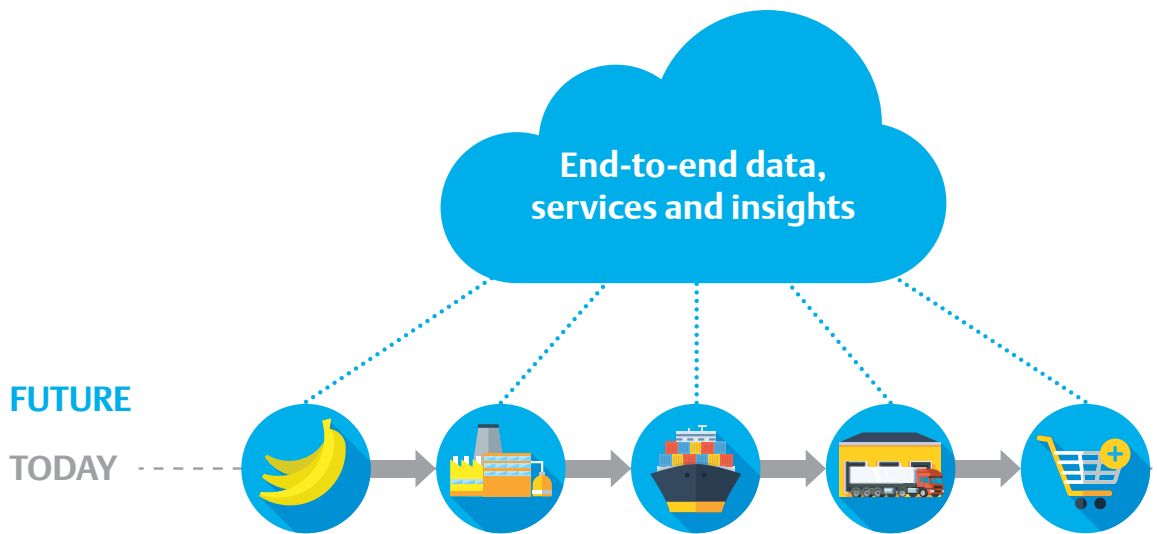

	Harvest	Processing	Transportation	Distribution	End Users
Copeland™ Compressors and Refrigeration Systems	✓	✓	✓	✓	✓
Vilter™ Industrial Refrigeration	✓	✓		✓	
Facility Management Systems and Dixell™ Controls	✓	✓	✓	✓	✓
GO Loggers and Trackers	✓	✓	✓	✓	✓
Cooper-Atkins™, ProAct™ and White-Rodgers™ Temperature Management	✓	✓	✓	✓	✓
ProAct™ Connectivity, Insights and Services			✓	✓	✓
Project Management				✓	✓

# Raising the Standard

*Copeland Scroll™ refrigeration K5 compressor builds upon foundation of reliability and efficiency*

In little more than five years since its introduction, the K5 compressor has set a high standard for efficiency and reliability in mission-critical refrigeration applications. Based on improvements to the Copeland Scroll™ compression platform, the innovative K5 quickly became a workhorse in supermarket refrigeration, restaurant walk-in coolers, and process chillers used in plants and environmental chambers.

Even though our industry has experienced a major transition over the last five years, the K5 has proved itself capable of meeting many emerging challenges. New lower-GWP refrigerants, tightening energy efficiency standards and rapidly changing retail dynamics are reshaping equipment selection criteria. To help our customers respond to changing market conditions, Emerson continues to make improvements to its K5 line of medium- and low-temperature compressors. The K5 has since evolved to deliver one of the refrigeration industry's most robust, energy-efficient performances today — all while enabling enhanced operational strategies and meeting a wide variety of application requirements.

## Top five refrigeration K5 benefits

Let's take a look at some of the features and capabilities that make the Copeland Scroll Digital™ K5 model one of the most trusted compressors in refrigeration.

**Proven reliability** — Copeland Scroll compression technology is at the core of the K5 platform.

- Up to 70 percent fewer moving parts than reciprocating compressors help reduce the chances for failure.
- Precision-machined scrolls deliver high efficiency and wear-in for improved performance over time.
- On-board CoreSense™ Diagnostics provide advanced protection to help ensure optimum system performance (see CoreSense sidebar).
- Liquid and vapor injection capabilities on the same compressor.

**Energy efficiency** — Innovative features improve upon scroll's inherent energy efficiencies.

- Vapor injection on low-temperature models improves efficiency by up to 20 percent and system capacity by up to 50 percent — up to 30 percent more efficient than hot-gas bypass



- Optimized scrolls and motors deliver up to a 10 percent efficiency gain over legacy Copeland Scroll compressors.
- Variable volume ratio (VVR) allows the compressor to run efficiently in high ambient environments and improves performance in low-condensing operation.

**Precise temperature and capacity control** — Digital compression technology provides several performance-enhancing capabilities.

- Simple digital modulation strategy enables varying capacities for fluctuating refrigeration loads.
- Precise case temperature control greatly improves product quality and minimizes frost accumulation.
- Continuous operation helps reduce compressor starts/stops for added reliability, reduced maintenance and increased compressor longevity.

**Compact design** — compared to its semi-hermetic counterparts, the K5 delivers big performance in a small package.

- Enhances application flexibility
- Improves serviceability throughout the lifecycle



ZF\*\*K5



ZFD\*\*K5



ZB\*\*K5



ZBD\*\*K5

**Wide application range** — the K5 line has been expanded to cover small- to large-capacity requirements in medium- and low-temperature applications.

- 7.5 to 17 hp, including five medium-temperature and four low-temperature displacements
- 58.9 to 115 kBTU/hr cooling capacity in medium-temperature with R-404A
- 32 to 54.1 kBTU/hr cooling capacity in low-temperature with R-404A and liquid injection
- 47.3 to 75.5 kBTU/hr cooling capacity in low-temperature with R-404A and vapor injection

For those seeking to move away from hydrofluorocarbon (HFC) refrigerants, the K5 line is certified for use with low-GWP, hydrofluoroolefin (HFO) alternatives R-448A and R-449A. In addition, the K5 is now manufactured in the United States, helping to reduce lead times for our North American customers.

If you're looking to reduce energy costs and improve operational reliability, the Copeland Scroll K5 line of compressors delivers leading refrigeration performance. [Click here](#) to learn more. 🌱

## The advantage of onboard CoreSense™ Diagnostics

CoreSense provides advanced features to help ensure maximum reliability and optimum system performance in the most demanding operating environments.

- Detects early warning signs of system issues, provides LED alerts and sends remote communications
- Protects compressor when catastrophic conditions are detected to help prevent costly failures
- Improves speed and accuracy of system troubleshooting by displaying fault codes

Diagnostic capabilities include:

- Discharge temperature protection
- Motor protection
- Asset information
- Compressor proofing
- Remote reset
- Current sensing diagnostics
- Modbus communications

## Proven energy efficiencies

Compared to semi-hermetic reciprocating compressors, some case studies have shown the K5 to be more energy-efficient in supermarket applications. The following Atlanta supermarket case study demonstrates the effectiveness of the K5 — using one low-temperature (LT) subcooled to 50 °F liquid and one medium-temperature (MT) rack.

*K5 compressors deliver significant energy improvements in an Atlanta supermarket case study.* ▶

### Atlanta Grocery Store Compressor Analysis

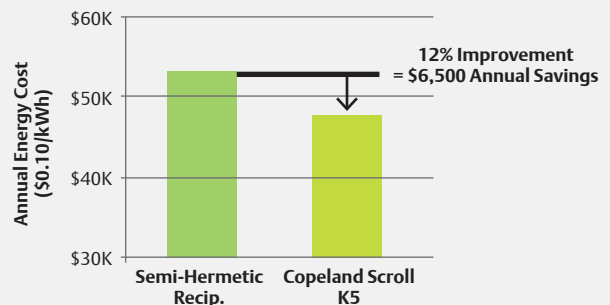

Analysis assumptions:  
Atlanta store with 1 LT (subcooled to 50 °F liquid) and 1 MT rack

# The Multiplex Revolution

Low-charge multiplex refrigeration systems are taking on energy, reliability and environmental challenges

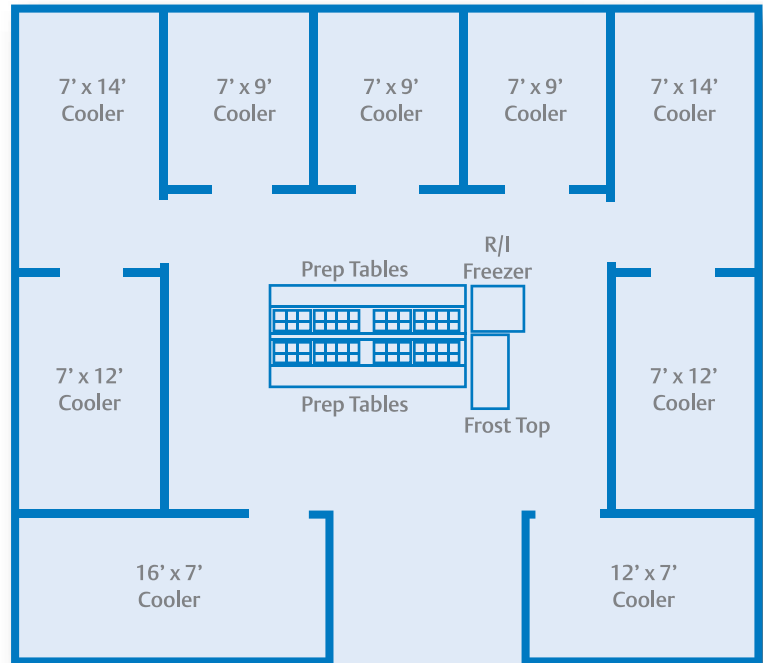

RDT Eco-Cool system

Increasing environmental concerns over refrigerant leakage and energy use have led to the development of innovative system configurations in the last two decades. Among the leading innovations are multiplex systems, which move the condensing unit outside of the conditioned space.

While the higher initial cost of these multiplex systems has historically been a hurdle — despite the significant financial and energy savings they offer over the life cycle of the system — the business case in their favor is changing rapidly as the Department of Energy tightens regulations for minimum efficiency levels. As these regulations become stricter, multiplex systems offer significant potential for savings from increased energy efficiency and lower operating costs.

Best of all, multiplex systems offer the potential for declining first costs as they are adopted by a growing number of users.

## Multiplex refrigeration systems

The term *multiplex refrigeration* refers to the use of one or more refrigeration compressors piped to common suction and discharge manifolds. These are mounted in a package that includes the piping, control valves, and electrical wiring needed to operate and control the refrigeration demand for display cases, walk-in coolers, freezers, ice-making heads, and other fixtures serviced by the system. Technologies that enable multiplex refrigeration include scroll compressors, floating head pressure control and compressor modulation.

Multiplex systems typically consist of one to four compressors sized for the maximum refrigeration load, though during most operations the load will be considerably less than the design value. The capacity of the compressors also increases at lower outdoor ambient temperatures.

Capacity control with a single fixed-speed compressor is accomplished by

on-off cycling over a larger suction pressure range to prevent short-cycling, which would shorten the life of the compressor. Multiple compressors can be used to operate at the highest possible suction pressure to maximize compressor operating efficiency.

Multiplex refrigeration also allows operation at low head pressure because of the ability of the system to continuously match (or float) capacity and load. This produces energy savings of 10 percent or more compared to systems operating at fixed higher minimum condensing temperatures. Even lower condensing temperatures are possible if scroll compressors are used.

## Suction piping considerations

Multiplex refrigeration systems operate several fixtures, each with liquid line solenoid valve and electronic expansion valve (EEV) control, from one or more compressors.

The temperature of individual fixtures is controlled with a thermostat opening in addition to closing the liquid line solenoid valve as necessary.

This type of system requires careful attention to design to avoid oil return problems and compressor overheating. Individual suction lines and risers are normally run from each fixture or group of fixtures for minimum pressure drop and maximum efficiency in oil return.

This provides excellent control so long as the compressor is operating at its design suction pressure, but there may be periods of light load when most or all of the liquid line solenoids are closed. Because of the fluctuations in refrigeration load caused by closing of the individual liquid line solenoid valves, some means of compressor capacity control must be provided. Capacity control must also prevent extreme variations in compressor suction pressure.

Where multiple compressors are used, cycling of individual compressors provides satisfactory control. Where multiplexing is done with a single compressor, the digital scroll has proven to be the most efficient means of capacity reduction, since this allows the compressor to operate continuously at a reasonably constant suction pressure.

### Scroll digital technology offers advantages

Traditional forms of modulation, such as hot gas bypass, unload without changing compressor capacity. Unfortunately, that means a compressor running at full capacity consumes the maximum amount of energy during the bypass cycle. Scroll digital compressors — which offer modulation from 10–100 percent — are a better alternative, allowing the system to automatically adjust capacity as needed while reducing energy consumption. Scroll technology is up to 30 percent more efficient than traditional methods of system modulation.

### EEVs enable low condensing refrigeration

EEVs allow refrigeration systems to operate at lower condensing temperatures, limiting energy consumption, improving system performance and reducing costs. For example, lowering the condensing temperature 20 degrees can potentially improve system efficiencies up to 35 percent.

Simply allowing saturated condensing temperatures to fall below the traditional 70 °F (21 °C) limit makes this possible. As the condensing temperature drops, so does the compressor wattage; meanwhile, the compressor BTU/hr increases. This also

increases the long-term reliability of the compressors, thanks to lower temperatures and discharge pressures. The resulting increase in capacity also reduces compressor run hours.

### Digital technologies enhance multiplex systems

New innovations in digital diagnostics make it possible for technicians to get in-depth system information for faster, more accurate decisions that improve compressor performance and reliability. This means contractors, homeowners, and businesses alike save valuable time and money.

Some diagnostic modules will even trip the compressor when certain severe alert conditions are detected. When the protector on a compressor opens and stops current flow into the compressor motor, the compressor shuts down. A trip condition will reset after a short cycle time or when the trip condition is no longer present.

Other emerging digital systems combine energy management with the ability to monitor facility systems, providing alerts when issues need attention. Such systems provide HVAC control, refrigeration system monitoring and control, as well as lighting control. Digital supervision systems can also monitor and report energy consumption, taking action to reduce energy demand during peak periods. This has a direct impact on utility bills by reducing total energy costs. 🌱

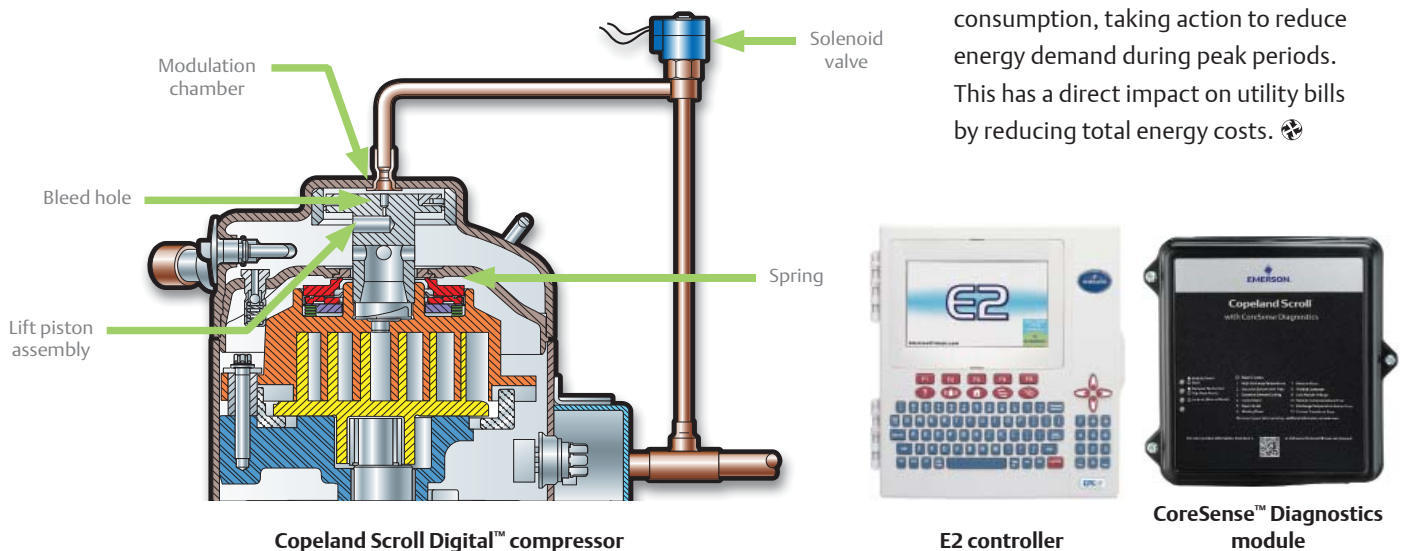

---

# *National Grocery Chain Makes Transition to Transcritical Refrigeration*

Phoenix-based grocery chain deploys its first CO<sub>2</sub> transcritical booster system in Atlanta store with Copeland Scroll™ and semi-hermetic compressors



In “Hotlanta” ambient temperatures routinely rise above 87.8 °F. That’s the critical point temperature for the emerging natural refrigerant CO<sub>2</sub> (R-744). When the temperature outside approaches this point, CO<sub>2</sub>-based commercial refrigeration systems begin to experience declining efficiencies. That’s why CO<sub>2</sub>-based refrigeration architectures are more common in cooler climates. And why CO<sub>2</sub> transcritical booster systems — which rely entirely on CO<sub>2</sub> — are not considered an obvious solution in places like Atlanta.

However, with increasing regulations prompting a shift toward sustainable alternative refrigerants, retailers are looking more closely at CO<sub>2</sub> transcritical booster systems to anchor their refrigeration operations, even in warmer climates.

With more than 200 U.S. locations, Sprouts Farmers Market, a healthy grocery chain that offers fresh, natural and organic foods, is among the first retailers in North America to do just that. They opened their first store in suburban Atlanta in July 2014, and when they did, they set out to prove CO<sub>2</sub> transcritical booster systems aren’t only for cool climates.

But Sprouts had clear business objectives for their CO<sub>2</sub> pilot program, as well. Their senior leadership wanted to reduce the company’s carbon footprint and mitigate regulatory compliance concerns. The forward-thinking grocery chain wanted to push the envelope and establish a sustainable refrigeration alternative in their new fleet of southern stores.

### Going green and keeping it fresh

When you’re a grocery chain focusing on selling fresh foods, fresh is the fundamental ingredient. That means your refrigeration system design has to be—above all else—reliable.

Like many food retailers, Sprouts has historically employed more traditional refrigeration systems based on common hydrofluorocarbon (HFC) refrigerants. These HFC systems operate with what’s traditionally seen as acceptable temperatures and pressures.

CO<sub>2</sub>’s low critical point temperature and high operating pressure (around 1,500 psig) are characteristically not found in traditional HFC-based refrigeration. These are the primary reasons for the reluctance to move toward CO<sub>2</sub>. But, with advances in system technology and architecture, CO<sub>2</sub> can be a game changer for retailers seeking to improve energy efficiencies, achieve sustainability targets and cross the finish line on regulatory compliance.

Changing their refrigeration philosophy and moving to a CO<sub>2</sub> transcritical system architecture was a giant step for Sprouts, especially for this store in the hot, humid climate of Atlanta.

To pull this off, they turned to OEM partner Hillphoenix, whom the company partnered with to earn an EPA GreenChill platinum certification in 2011. And Hillphoenix, seeing the challenge presented by installing a CO<sub>2</sub> transcritical booster system in a warm climate, turned to Emerson.

### Transcritical technology in action

Emerson, Hillphoenix and Sprouts all shared the same goal: show the industry it’s possible to operate an efficient refrigeration system in higher ambient temperatures using CO<sub>2</sub> exclusively.

A key enabling feature of the CO<sub>2</sub> transcritical booster system is an adiabatic condenser, which was designed to operate in high ambient temperatures. Adiabatic condenser cooling is the process of spraying water



*Hillphoenix warm climate CO<sub>2</sub>-based transcritical booster system installation utilizing Emerson components*



into the air supply of an air-cooled condenser to pre-cool the air and improve refrigeration efficiency. The goal of this condenser technology is to keep the CO<sub>2</sub> below its critical point, thus maximizing system efficiencies.

Hillphoenix's rack refrigeration system featured four Copeland™ semi-hermetic transcritical CO<sub>2</sub> compressors and three Copeland Scroll ZO compressors. Both models were designed for CO<sub>2</sub>'s high-pressure requirements and benefit from its thermal properties.

Emerson's E2 Facility Management System was installed to oversee the CO<sub>2</sub> transcritical booster system, manage nearly 50 electronic case control units and optimize the facility's overall energy management profile. The E2 system helps improve performance in multiple ways:

- 1) Controls the variable speed of the fans on the adiabatic condenser in response to operating conditions
- 2) Optimizes compressor coefficient of performance by regulating system discharge pressures via Emerson's high-pressure CO<sub>2</sub> controller
- 3) Provides complete oil management control of all CO<sub>2</sub> refrigeration compressors
- 4) Communicates with and captures information from individual case control units
- 5) Provides complete control of building HVAC and refrigeration systems, and supports the retailer's energy and maintenance reduction strategies

The E2 system also allows Sprouts operators to run diagnostics, monitor the system remotely through Emerson's ProAct™ Service Center and, if necessary, shut down the system components before failure.

The condenser manages both low- and medium-temperature refrigeration requirements on the same system using only CO<sub>2</sub> as the refrigerant, another unique aspect to the transcritical booster system. Running both requirements from the same condenser enhances the efficiency of the system across the store.

### **Easing concerns**

CO<sub>2</sub> transcritical booster systems have been used in Europe for nearly a decade. Adoption by the U.S. refrigeration industry has been slower due to a general apprehension about new (and, to many, unknown) technology.

It's understandable why stateside end users are hesitant to switch to CO<sub>2</sub> transcritical booster systems. Concerns over operating pressures, maintenance levels and energy have prompted careful and steady evaluations to understand the true cost of ownership for their enterprises.

Emerson technology helped ease those concerns for Sprouts. Their Atlanta-area store is operating efficiently and effectively on the transcritical system.



## Emerson equipment portfolio

The pilot CO<sub>2</sub> transcritical booster system designed for Sprouts' Atlanta store utilizes multiple Emerson components, including:

- 1. Copeland Scroll ZO compressors** — for low-temperature refrigeration requirements (freezers)
- 2. Copeland semi-hermetic transcritical CO<sub>2</sub> compressors** — for medium-temperature refrigeration requirements (dairy, produce and meat cases); includes variable frequency drives to prevent the compressors from cycling on and off too frequently
- 3. CoreSense™ technology for Copeland compressors** — advanced compressor diagnostics, protection and communications technology that allows technicians to make faster, more accurate decisions, resulting in improved compressor

performance and reliability; present on all store compressors

- 4. E2 Facility Management System** — provides complete CO<sub>2</sub> transcritical booster system optimization and facility-wide energy management
- 5. High-pressure CO<sub>2</sub> controller** — optimizes high side pressures and liquid quality to the cases
- 6. XM Series case controls (pulse-width modulated)** — integrates with the E2 system to maximize operating efficiencies through tighter temperature controls; present on nearly 50 cases

**Discharge air controller (not shown)** — operates in unison with the E2 system and is capable of controlling heat and cool stages, fans, dehumidification devices and economizers using on-board I/O

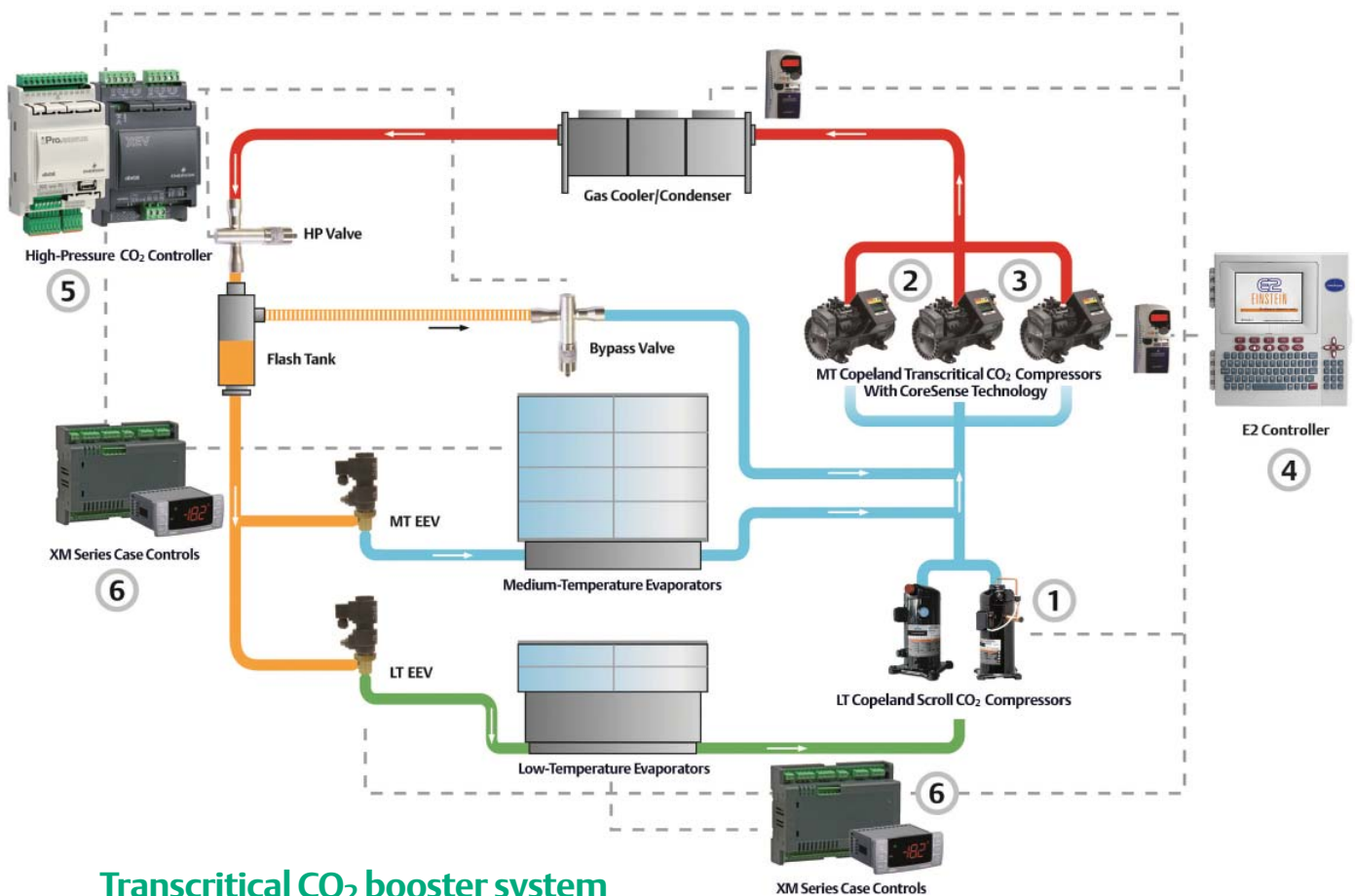

Transcritical CO<sub>2</sub> booster system

# Food quality is a differentiator

Brand reputations are built on the promise of delivering consistently exceptional food and dining experiences.



Willing to pay more for **healthier foods**



Consider food quality, taste and appearance as **key dining criteria**



Global sales of healthy food products were estimated to reach **\$1 trillion** by 2017

*Protecting food quality and sustainability*

# Consumers demand fresh, healthy convenience

As consumer preferences evolve, retailers attempt to meet rising expectations with new format and merchandising strategies.



Ingredient-savvy, **health-conscious consumers** demand fresh, organic and locally sourced foods



**67 percent** of grocery stores' perimeter (fresh) categories sales have increased in the last 12 months



**61 percent** of millennials purchase prepared food at a convenience store at least once a month

*Ensuring human comfort and health*

# Emerson solutions:

## Conditions control, management and insights

- Electronics and facility controls
- Oversight services for cargo
- ProAct connectivity and monitoring
- ProAct software, apps and services
- ProAct service center
- Transformative Wave HVAC and RTU management systems
- Cooper-Atkins™ temperature management systems



## Food safety and quality

- Copeland efficient compressors and refrigeration systems
- Cooper-Atkins temperature monitoring and management
- Dixell™ parametric, system and facility controls
- Electronics and controls
- Cargo Solutions™ trackers and loggers
- ProAct connectivity and monitoring
- ProAct alarm management and food quality services
- Vilter™ industrial refrigeration

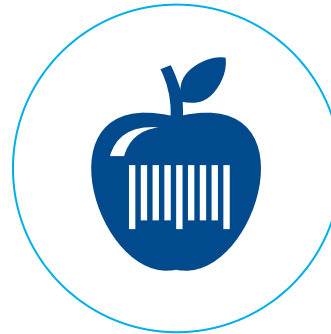

## Infrastructure and maintenance

- Copeland efficient compressors and refrigeration systems
- Dixell parametric, system and facility controls
- Electronics and facility controls
- Project management services
- ProAct connectivity and monitoring
- ProAct Site Manager, apps and PSC services
- ProAct software, apps and services for facilities
- Transformative Wave HVAC and RTU management systems
- Vilter industrial refrigeration



## Energy and sustainability

- Copeland efficient compressors and refrigeration systems
- Copeland alternate refrigerant compressors and systems and refrigeration systems
- Dixell parametric, system and facility controls
- Electronics and controls
- Commissioning services
- ProAct connectivity and monitoring
- ProAct reporting, services and insights
- Transformative Wave HVAC and RTU management systems



# Less Is More

Copeland Scroll™ compressors with liquid injection are now available in fractional horsepower range

When it comes to regulatory compliance, food-service refrigeration equipment manufacturers will continue to face an ever-changing mix of state, federal and global requirements. Transitioning to lower-GWP refrigerants and meeting new energy efficiency standards are becoming top design priorities. The challenge for foodservice OEMs is to design new condensing units and stand-alone equipment that comply with both requirements.

Our new ¾ to 1½ horsepower (HP) offerings extend the existing Copeland Scroll ZF\*KA and ZB\*KA compressor lines, allowing OEMs to combine compliance into a single design cycle for smaller low- and medium-temperature applications. As with any Copeland Scroll compressor, these smaller offerings deliver high efficiencies and reliable performance.

As the EPA phases down the use of hydrofluorocarbons (HFCs) with higher global warming potential (GWP), new refrigeration platforms must be designed to accommodate the performance characteristics of lower-GWP alternatives. The new fractional HP Copeland Scroll compressors are rated for use with new alternatives R-448A/449-A as well as existing lower-GWP HFCs such as R-407A.

## Liquid-injected for low-temperature efficiencies

Walk-in freezers that rely on outdoor condensing units will require compressors that can mitigate the higher discharge temperatures produced when using new refrigerant alternatives in low-temperature applications. The Copeland Scroll ZF\*KA fractional HP models utilize liquid-injection technology to cool discharge temperatures and reduce compressor stress. Traditional hermetic reciprocating models will require



  
Energy Ready

  
Refrigerants Ready

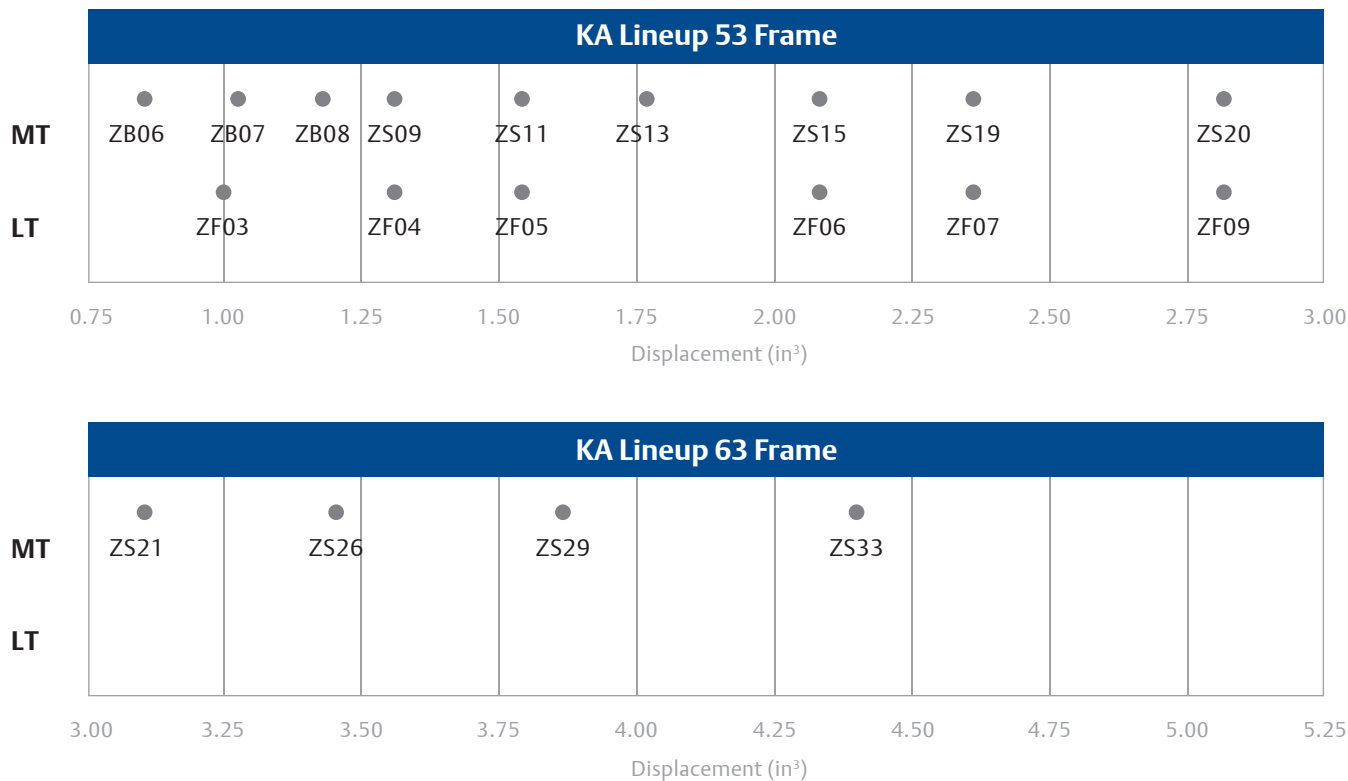

additional modifications and heat-reduction strategies in these low-temperature scenarios that can't match the inherent simplicity and efficiency advantages of Copeland Scroll technology.

Copeland Scroll ZF\*KA fractional HP compressors are the basis of Emerson's Outdoor Refrigeration Unit X-Line Series, enabling it to simultaneously meet both DOE (AWEF efficiency) and EPA (lower-GWP refrigerant) requirements in low temperatures. Other condensing unit manufacturers can achieve similar benefits with the expansion of Copeland Scroll into smaller HP ranges.

#### Wide applicability in medium temperatures

For medium-temperature, walk-in coolers, the new fractional HP ZB\*KA compressors deliver enhanced AWEF efficiencies in WICF condensing units. It's important to note that incumbent hermetic reciprocating compressors cannot achieve the same efficiencies without modifications to other system components (e.g., coils, cooling fans, etc.). Patented Copeland Scroll technology enables significant efficiency improvements in medium-temperature WICF applications without the investments in additional components or engineering, design and development (ED&D) costs.

The new ZB\*KA compressors represent an extension of the medium-temperature line of compressors to better serve today's wide range of walk-in cooler requirements. OEMs can now integrate reliable Copeland Scroll technology into their complete lineup of walk-in refrigeration equipment, while achieving compliance with environmental and energy efficiency regulations.

#### Simplify the design cycle

As foodservice refrigeration OEMs complete the design cycles needed to comply with EPA and DOE regulations over the next few years, the new fractional HP Copeland Scroll compressors will offer them many distinct advantages. In low-temperature, walk-in applications, the liquid-injected ZF\*KA models will enable reliable operation without the need for complex heat-mitigation techniques. And in medium temperatures, where larger coils, evaporator fans and other components may be needed to meet AWEF targets, the efficiency of scroll technology alone will often get the job done. Compared to its hermetic reciprocating counterparts, Copeland Scroll compressors are simpler to incorporate into new designs without additional engineering, development and design costs. 🌐

---

# State of the Art Sustainability

Multiplex refrigeration system lays foundation for  
Café's green mission



If you're a restaurant owner who decides to put the word "green" in your name, sustainability better be a significant part of your culinary story. After all, when patrons dine at a green restaurant, their standards are raised. They expect locally sourced, natural, organic and sustainably raised foods. And they want a dining experience in an environment that exudes green and supports sustainable principles. The Green Sage Café in Asheville, N.C., embraces this challenge with a green vision that permeates every facet of their operation.

Owned and operated by Randy Talley and Roger Derrough, the Green Sage Café has three locations across Asheville. While their first café incorporated many green elements, its refrigerated fixtures each operated on independent compressors — a refrigeration architecture that Talley identified as an area for improvement in their second restaurant.

"With 10 compressors running on everything from under-counter sandwich stands to reach-in refrigerators, there was a lot of heat being generated and energy wasted, not to mention a lot of noise rattling around the restaurant," he said.

Talley leaned on his background in the natural foods grocery industry to find a better solution. There he had utilized rack refrigeration systems with minimal compressors to provide cooling for multiple fixtures. He wanted to implement a similar architecture — now commonly referred to as multiplexing — but wasn't sure if this technology would translate into his foodservice applications. That's when Talley tapped Refrigeration Design Technologies (RDT), experts in eco-friendly refrigerated system design, to implement a system that would take his second location to the next level of energy efficiency.

"Our goal was to create the greenest restaurant possible. We wanted to cut energy consumption in half without compromising the quality of the food we're serving," Talley said.

### Keeping (Eco)-Cool under pressure

Brent Dyess, RDT's president, knew that Talley's lofty goals were within reach. Dyess selected RDT's proven Eco-Cool refrigeration system based on the Copeland Scroll Digital™ compressor for the second Green Sage Café location. Eco-Cool was specifically designed to meet the demands of environmentally responsible foodservice outlets, relying on lean multiplex refrigeration architecture to deliver the highest degree of energy efficiency.

The Green Sage Café's unique energy and environmental requirements made it an ideal candidate for the Eco-Cool system. The system minimizes the compressors needed to

provide refrigeration, servicing eight fixtures in the café's medium-temperature suction group with one 4 HP Copeland Scroll Digital compressor. With their ability to digitally modulate capacity from 10 to 100 percent, Copeland Scroll Digital compressors enable precise matching of refrigeration requirements to the variable operating loads typical of a foodservice application.

Dyess ensured Talley that the benefits of this multiplex architecture would be immediately apparent.

"Instead of eight compressors kicking on and off, pulling full run-load amps each time, you have a single compressor running at only the capacity needed to meet the load. And if all fixtures call for refrigerant, that compressor is capable of handling everything at the same time," Dyess explained.

The medium-temp fixtures covered by the 4 HP Copeland Scroll Digital compressor included:

- Walk-in cooler
- Sandwich stands (2)
- Reach-in refrigerators (2)
- Griddle stand
- Product merchandiser
- Beer cooler

---

*"Our goal was to create the greenest restaurant possible. We wanted to cut energy consumption in half without compromising the quality of the food we're serving."*

*— Randy Talley, Green Sage Café*

Dyess explained that the digital application also substantially reduces the piping required in conventional systems. "Considering we have eliminated numerous one-to-one piping scenarios, we can run piping in a more efficient trunk line configuration," he said.

### Surprising energy savings

Dyess originally estimated that the system would provide the restaurant up to 30 percent in annual energy savings. But when

*“If our customers see the value in reusing a natural by-product of the refrigeration system, then we recommend it.”*

— Brent Dyess, RDT

the Green Restaurant Association (GRA) evaluated the Green Sage Café’s environmental profile for certification purposes, they commissioned RDT to perform an independent, third-party study on the Eco-Cool system. The results were surprising.

The UL energy study simulated a foodservice application, comparing a multiplex system (with one Copeland Scroll Digital compressor servicing six fixtures) to a conventional system. The study replicated actual foodservice conditions, such as varying demands and frequent refrigerator door openings and closings. The data revealed that in 90 °F ambient conditions, the Copeland Scroll Digital-based Eco-Cool system delivered 48 percent energy savings.

The study demonstrates that as the ambient temperature rises above 90 °F, the energy savings will decrease slightly. But as

Dyess explained, at temperatures below 90 °F, the potential for energy savings will continue to rise above the 48 percent mark.

**Keeping cool and getting into hot water**

The multiplex refrigeration system also helped Green Sage Café owners check other significant items off their sustainability list. By placing the Eco-Cool unit outside the restaurant and removing condenser surface areas that are present on each fixture in conventional systems, they eliminated 53,856 BTUH of heat, or the equivalent of 4.5 tons of air conditioning. Not only does this contribute to the café’s eco-friendly footprint, it helps create a better dining experience for patrons and improved working conditions for the staff.

Another advantage of the Eco-Cool refrigeration system was its ability to capture waste heat and divert it into a heat exchanger that provided heating for the restaurant’s hot water tank.

“We had used solar panels for hot water heating in our first location, but this heat reclamation system was even more effective,” Talley explained. “This system takes care of all of our hot water requirements,” he added.

For the RDT team, the concept of heat reclamation just makes good environmental sense.

“If our customers see the value in reusing a natural by-product of the refrigeration system, then we recommend it,” Dyess said. “Green Sage Café had the vision and commitment to utilize every available natural resource,” he added.

**Energy consumption comparison: Copeland Scroll Digital compressor vs. conventional system**

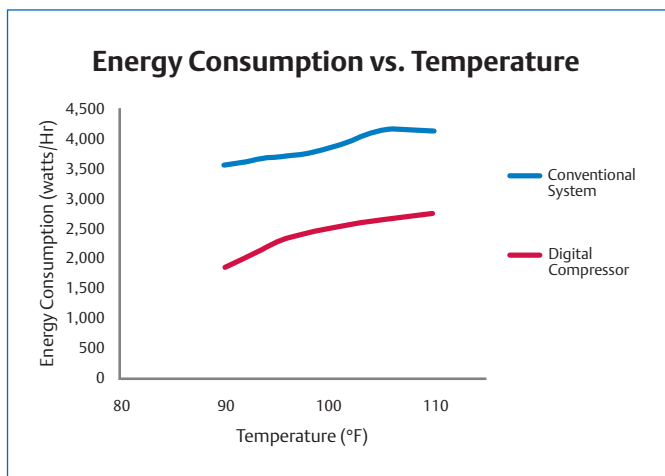

Temperature (°F)	Energy Consumption (watts/hr)				
	90	95	100	105	110
Conventional System	3,571	3,712	3,849	4,143	4,142
Digital Compressor	1,852	2,275	2,508	2,648	2,756
Delta	1,719	1,437	1,341	1,495	1,386
Energy Saved (%)	48%	39%	35%	36%	33%

An independent UL study of RDT’s Eco-Cool unit compares a conventional compressor system with the Copeland Scroll Digital compressor. At 90 °F ambient temperatures, the digital scroll compressor saves 48 percent on energy.





### Certifiably green

With the Eco-Cool refrigeration system as a green foundation, the Green Sage Café incorporated additional sustainable elements, including: solar panels, energy-efficient dishwashers and LED lighting. In recognition of its sustainable, state-of-the-art vision, the Green Sage Café earned the distinction of being the GRA's first four-star certified Green Restaurant in the South.

As a result of their success, many other restaurants in the Asheville area have taken on the green mantle. And with the help of grants from the state of North Carolina, 17 restaurants (including the first two of the Green Sage Café's three locations) are now offering sustainable, natural food-based fare in Asheville. The city has become such a bastion of green culinary principles that it was recently named the country's first Green Dining Destination by the GRA. 🌱



*Designed with a Copeland Scroll Digital compressor, the Eco-Cool system from RDT serves as a cornerstone of the Green Sage Café's sustainability strategy.*

# Copeland Scroll™ low-temperature compressors for refrigeration



Fixed/ Modulation	Fixed	Fixed	Fixed	Modulation	Fixed	Modulation
<b>ZO**K/ZOD**K</b> Low Temperatures -58°F to -13°F	<b>ZF**KA</b> Low Temperatures -40°F to 10°F Small Scrolls	<b>ZF**K4</b> Low Temp/Liquid Injection -40°F to 0°F Med Temp / Liquid Injection -10°F to 45°F * With Sight Glass	<b>ZF**KV</b> Enhanced Vapor Injection (EVI) With Sight Glass -40°F to 0°F *	<b>ZFD**KV</b> Enhanced Vapor Injection (EVI) 10% to 100% Digital Modulation With Sight Glass -40°F to 0°F *	<b>ZF**K5</b> Vapor or Liquid Injection CoreSense™ Diagnostics With Sight Glass -40°F to 0°F *	<b>ZFD**K5</b> Vapor or Liquid Injection CoreSense™ Diagnostics 30% to 100% Digital Modulation With Sight Glass -40°F to 0°F *

\*Evap temperature can vary per refrigerant

## HP/Models/Plant

<b>1.0 – 6 HP</b> ZO21, 34, 45 58, 88, 104 ZOD34, 58, 104 N. Ireland	<b>1.0 – 3.5 HP</b> ZF03, 04, 05, 06, 07, 09, 11 Lebanon, MO	<b>4.0 – 8.0 HP</b> ZF13, 15, 18, 25, 28 Sidney, OH / N. Ireland	<b>4.0 – 8.0 HP</b> ZF13, 18, 25, 28 Sidney, OH / N. Ireland	<b>4.0 – 7.5 HP</b> ZFD13, 18, 25 Sidney, OH / N. Ireland	<b>8.0 – 17 HP</b> ZF34, 41, 49, 54 Sidney, OH / Belgium	<b>13.0 HP</b> ZFD41K5 Sidney, OH
--	---	--	--	---	--	---

## Refrigerants

R-744 (CO <sub>2</sub> )	R-404A, 407A/C/F, 448A, 449A, 507	R-22, 134a, 404A, 407A/C/F, 448A, 449A, 507	R-22, 404A, 407A/C/F, 448A, 449A, 507	R-22, 404A, 407A/C/F, 448A, 449A, 507	R-22, 404A, 407A/C/F, 448A, 449A, 507	R-22, 404A, 407A/C/F, 448A, 449A, 507
--------------------------	--------------------------------------	---	--	--	--	--

## Applications

Supermarket, Reach-In/Walk-in Freezer, Environmental Chambers, Industrial/Medical Applications, Transportation

Emerson is assessing the next level of lower-GWP refrigerants for the scroll portfolio. Contact us at E360@emerson.com to learn more.

# Copeland Scroll™ medium-temperature compressors for refrigeration



Fixed		Modulation		Fixed		Modulation	
<b>ZB**KA</b> Smallest Displacement in Refrigeration Scroll -10°F to 45°F	<b>ZS**KA</b> Extended Medium Temperature -25°F to 45°F	<b>ZS**K4</b> Extended Medium Temperature With Sight Glass -25°F to 45°F	<b>ZB**KC</b> With Sight Glass -10°F to 45°F	<b>ZB**KC</b> Advanced Scroll Temperature Protection (ASTP) With Sight Glass -10°F to 45°F	<b>ZBD**KC</b> 10% to 100% Digital Modulation With Sight Glass -10°F to 45°F	<b>ZB**K5</b> CoreSense™ Diagnostics With Sight Glass -10°F to 45°F	<b>ZBD**K5</b> CoreSense™ Diagnostics 30% to 100% Digital Modulation With Sight Glass -10°F to 45°F

## HP/Models/Plant

<b>0.75 – 1.25 HP</b> ZB06, 07, 08 Lebanon, MO	<b>1.3 – 4.5 HP</b> ZS09, 11, 13, 15, 19, 20, 21, 26, 29, 33 Lebanon, MO	<b>4.0 – 6.0 HP</b> ZS30, 38, 45 Sidney, OH / N. Ireland	<b>4.0 – 9.0 HP</b> ZB29, 30, 38, 42, 45, 48, 57 Sidney, OH / N. Ireland	<b>9.0 – 15 HP</b> ZB66, 76, 88, 95, 114 Sidney, OH / Belgium	<b>3.0 – 10 HP</b> ZBD21, 30, 38, 45, 57 Sidney, OH / N. Ireland ZBD58, 76 Sidney, OH	<b>8.0 – 15 HP</b> ZB58, 66, 76, 95, 114 Sidney, OH / Belgium	<b>10 &amp; 15 HP</b> ZBD76, 114 Sidney, OH
--	---	--	---	--	---	--	---

## Refrigerants

R-22, 134a, 290 404A, 407A/C/F, 448A, 449A, 507	R-22, 134a, 404A, 407A/C/F, 448A, 449A, 507	R-22, 404, 507, 134a	R-22, 134a, 290 404A, 407A/C/F, 448A, 449A, 507	R-22, 134a, 404A	R-22, 134a, 404A, 407A/C/F, 448A, 449A, 507	R-22, 134a, 404A, 407A/C/F, 448A, 449A, 507	R-22, 134a, 404A, 407A/C/F, 448A, 449A, 507
---	---	-------------------------	---	------------------	---	---	---

## Applications

Supermarket, Reach-In/Walk-in Coolers, Soft Serve /FCB, Transportation

Emerson is assessing the next level of lower GWP refrigerants for the scroll portfolio. Contact us at E360@emerson.com to learn more.

## Emerson Commercial and Residential Solutions

Emerson creates value for customers by innovating the solutions that will become their successes. We will continue to offer the technologies and services that keep homes and businesses running smoothly while creating comfortable, controllable environments with our energy-efficient HVACR solutions. Look to Emerson to solve the toughest industry challenges with our market-proven compressors, controls, thermostats and related equipment. Learn more at Emerson.com.

The Emerson Commercial & Residential Solutions business platform includes leading product brands such as: Copeland™, ProAct™, Sensi™, RIDGID® and InSinkErator®.

Commercial & Residential Solutions is focused on delivering value through:

- Ensuring human comfort
- Protecting food quality and sustainability
- Advancing energy efficiency and environmental conservation
- Creating sustainable infrastructure
- Innovating at The Helix

## We'd like to hear your feedback.

Thank you for reading this edition of *E360 Outlook*! At Emerson, we believe the challenges faced by the refrigeration industry cannot be solved in a vacuum. Only through collaboration and a commitment to innovation will we discover answers to the difficult questions before us.

We hope the information provided here will spark conversations and open all of our eyes to new perspectives. But for that to happen, we all need to contribute. And that starts with you. Feel free to contact us with your feedback, questions and insights. We look forward to hearing from you.

 [facebook.com/CopelandScrollCompressors](https://www.facebook.com/CopelandScrollCompressors)  
[facebook.com/EmersonCommercialResidentialSolutions](https://www.facebook.com/EmersonCommercialResidentialSolutions)

 [twitter.com/CopelandScroll](https://twitter.com/CopelandScroll)  
[twitter.com/EmersonFresh](https://twitter.com/EmersonFresh)  
[twitter.com/EmersonComRes](https://twitter.com/EmersonComRes)

 [Emerson Commercial and Residential Solutions](https://www.linkedin.com/company/emerson-commercial-and-residential-solutions)

 <https://EmersonClimateConversations.com>

 [Emerson Commercial and Residential Solutions](https://www.youtube.com/emerson-commercial-and-residential-solutions)

## E360 resources are available to you each and every day online.

Visit [Climate.Emerson.com/E360](https://Climate.Emerson.com/E360) or the Emerson Commercial and Residential Solutions YouTube channel.



E360 Forums

[Climate.Emerson.com/  
E360Forums](https://Climate.Emerson.com/E360Forums)



E360 Webinars

[Climate.Emerson.com/  
E360Webinars](https://Climate.Emerson.com/E360Webinars)



E360 Articles

[Climate.Emerson.com/  
E360Articles](https://Climate.Emerson.com/E360Articles)



E360 Content Hub

[Climate.Emerson.com/  
E360ContentHub](https://Climate.Emerson.com/E360ContentHub)